

# TC490 TC940 Time Relay USER GUIDE's

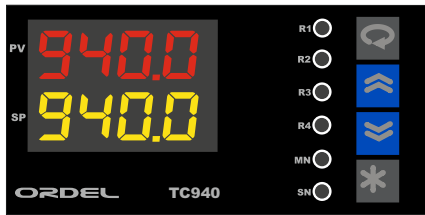

## DEVICE DESCRIPTION

Model TC490 and TC940 devices are designed for applications which requires different timing processes. These devices may be operated in four different modes by the usage of two timer and time unit can be chosen as seconds, minutes or hours in the interval of 0.00-99.99 and 0-9999.

100-240Vac/dc universal and 24Vac/dc power voltage models are

## SAFETY PRECAUTIONS

- ☞ Before using the device, please read the warnings below and this guide carefully.
- ☞ The accidents and damages resulting from not following the warnings included in this guide are under user's responsibility.
- ☞ Take the necessary precautions in order to prevent accidents and damages that may result in case the device gets faulty.
- ☞ Do not use this device in environments where flammable or explosive gases exist.
- ☞ Do not allow metal fragments or lead wire scraps or liquid matters to fall inside this device.
- ☞ Do not touch the terminals while the device is energized (power on)
- ☞ Device will be out of guarantee when it gets faulty resulted from misuses.
- ☞ Do not power up the device before the connections related with the device are performed in accordance with connection diagram.

## INDICATOR CHARACTERS

### SYMBOLISATION OF ALPHABETICAL CHARACTERS

A	B	C	D	E	F	G	H	I	J	K	L	M
A	b	C	d	E	F	G	H	I	J	K	L	ñ
N	O	P	Q	R	S	T	U	V	W	X	Y	Z
n	o	P	q	r	s	t	U	u	v	w	x	z

## PRODUCT CODE

TC490 - /  
TC940 -

### Supply Voltage

0 = 100-240Vac/dc ( Universal )  
1 = 24Vac/dc

### First Output Module ( DO1 )

1 = NO Contact  
2 = NO/NC Contact  
3 = Pulse ( to drive SSR )

### Second Relay Module ( DO2 )

0 = N/A  
1 = NO Contact  
2 = NO/NC Contact  
3 = Pulse ( to drive SSR )

## CONNECTION DIAGRAM

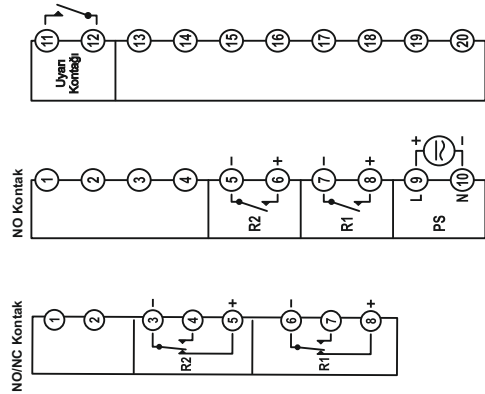

## DISPLAY and BUTTONS

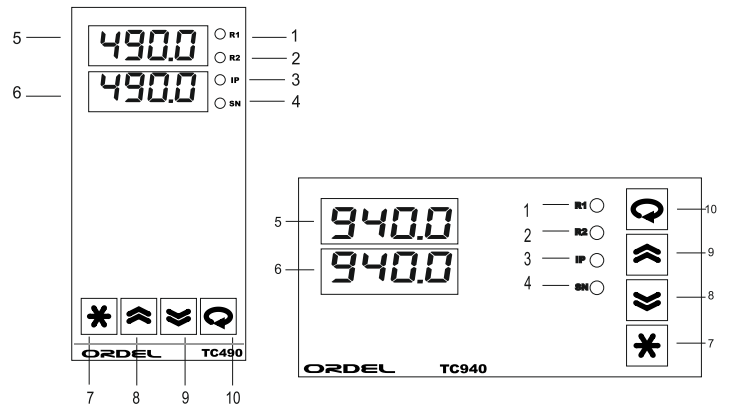

1	UPPER DISPLAY	It displays the remaining time of the first timer or the parameter names.
2	LOWER DISPLAY	It displays the remaining time of the second timer or the parameter names.
3	O1 LED	It indicates the state of first output module (DO1).
4	O2 LED	It indicates the state of second output module (DO2).
5	O3 LED	Not available in this model.
6	O4 LED	Not available in this model.
7	IP LED	It indicates the state of alarm contact (DI).
8	SN LED	It blinks with a periode of 1 second while the time passes.
9	ASTERIX BUTTON	It is used to return to Operator-Screen.
10	UPPER ARROW	It is used to increase the time that will be set or the parameter value.
11	LOWER ARROW	It is used to decrease the time that will be set or the parameter value.
12	ENTER BUTTON	It is used to access the next parameter.

## TECHNICAL SPECIFICATIONS

Supply Voltage	100-240Vac/dc: +%10 -%15	24Vac/dc: +%10 -%20
Power	5W,8VA	
Output Modules (	NO Contact: 250Vac	NC Contact: 250Vac
Contact Lifetime	Without Load: 10.000.000 sw, With 250Vac 3A res. load: 100.000 sw	
Memory	100 year, 100.000 renewals	
Accuracy	+/- %0,01	
Environment	Operation: -10...+55C, Storage: -20...+65C	
Protection	IP20	
Dimensions	490/940: Width: 48/96 mm, Height: 96/48 mm, Depth: 110mm	
Panel Cut-Out	490/940: 45/92+/-0,5 mm x 92/45 +/-0,5 mm	
Weight	320 gr	

## USAGE

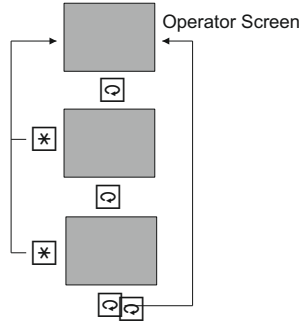

While in normal operation state, upper display displays the remaining time, lower display displays the remaining time of second timer. This view is called Operator-Screen.

While in Operator-Screen, pressing the "→" key brings the set value of first timer (SET.1). pressing the "←" key for the second time brings the set value of second timer (SET.2).

Any set value can be changed by pressing "↑" or "↓" keys.

In order to return the Operator-Screen while in any time, "★" key can be used.

Operation mode of the device, time unit and decimal point are set using the parameters that can be found in Configuration-Page.

Accessing configuration page and the parameters in this page are described in the next section.

## ACCESS to CONFIGURATION PAGE

In order to access the configuration page, just after energizing the device, in the interval of two seconds ( while 8.8.8.8. Is displayed on screen), "★" and "→" keys should be pressed simultaneously and held while opening message appears on screen.

In configuration page, first display displays the parameter name and the second displays the parameter value. "↑" and "↓" keys change the parameter value, "→" parameter is used to access the next parameter and "★" key is used to exit from Configuration-Page.

## CONFIGURATION PAGE PARAMETERS

Par. 01		Operating Mode of First Timer ( Ref Table-1 ) Setting Preferences : 0 - 5
Par. 02		Time Unit of First Timer Setting Preferences : SEC = Second MIN = Minute HR =
Par. 03		Decimal Point of First Timer Setting Preferences: 0 - 2
Par. 04		Operating Mode of Second Timer ( Ref Table-1 ) Setting Preferences : 0 - 5
Par. 05		Time Unit of Second Timer Setting Preferences : SEC = Second MIN = Minute HR =
Par. 06		Decimal Point of Second Timer Setting Preferences : 0 - 2

## OPERATION MODES

MODE 0: When the alarm contact is ON, the time count and the selected relay are ON. At the end of the time, the relay turns OFF.

MODE 1: When the warning contact is ON, the relay is ON at the end of the timer and time. The relay output is interrupted when the alarm contact is interrupted.

MODE 2: Starts counting time when a warning contact is set and stopped. The relay is energized until the warning contact is ON and the time is expired.

MODE 3: If this timer is selected, the timer starts counting from the moment the other timer's timer expires. During this time the relay will be ON. At the end of the time the relay output is OFF. If the two timers' mode is set to 3, the two timers will run continuously as opposed to turning off the unit's energy.

MODE 4: When the up arrow key is pressed, the timer starts counting and at the end the relay turns ON. The relay is OFF when the down arrow key is pressed. If the up arrow key is pressed while counting time, counting is canceled and relay turns OFF.

MOD 5: Starts counting time when the up arrow key is pressed. The relay turns ON when counting time. At the end of time the relay turns OFF. If the down arrow key is pressed while counting time, counting is canceled and relay turns OFF.

TABLE1

Table-1	MOD0 (MD.n = 0)	MOD1 (MD.n = 1)	MOD2 (MD.n = 2)	MOD3 (MD.n = 3)
WARNING (DI)				
OUTPUT (DO)				

"T" represents the set time and "t" represents the remaining time. Hatched line is the active time line.

Operating modes in table are valid for both timers. "n" represents the timer number.

In MOD3, (MD.n = 3) "td=0" is the time that other timer becomes "0". Namely, if a timer is wanted to run after other timer, MOD3 should be selected. If both timers is wanted to be run in order, MOD3 should be selected for both timers.