

## Standard Control Device



# SC771

### Device Features

- 2 pcs 4 Digit Display
- 3 pcs LED Display
- 1 pcs Transmitter Supply Output (24VDC)
- 1 pcs Universal Sensor Input (TC, RT, mA, mV, V)
- 1 pcs Analog Output (0/4-20mA.0/2-10V)
- 1 pcs RS485 Communication Unit
- 3 pcs Relay or Logic Output (24VDC)
- 100-240V AC/DC Universal or 24V AC/DC Supply Voltage
- Isolation Between Input/Output Modules

- Auto-Tuning (Automatic settings of PID parameters)
- Sensor Fault Detection
- 9 Different Relay Functions
- ON/OFF, P, PI, PID Controls
- Linear and Time Proportional Control Output
- 100ms Sampling and Control Cycle
- Standard MODBUS RTU communication protocol
- Configuration via computer

SC771 devices are 72 x 72 mm in size. They are designed to measure the temperature, pressure, speed, level, humidity, current, voltage, resistance and other physical units, as well as the on / off and PID control of many process variables in industrial environments. They are completely modular and each module can be configured individually. It is used in Food, Plastic, Iron Steel, Chemistry, Metallurgy, Cement, Ceramic, Petro-Chemistry, Refineries, Glass and other industries. They are ergonomic devices whose compliance with international standards, reliability and ease of use have been ensured at the design stage.

### Input Types

Sensor Type	Standard	Min.	Max.
Type-T ( Cu-Const )	IEC60584	-200 °C	300 °C
Type-U ( Cu-Const )	IEC60584	-200 °C	600 °C
Type-J ( Fe-Const )	IEC60584	-200 °C	800 °C
Type-L ( Fe-Const )	IEC60584	-200 °C	900 °C
Type-K ( NiCr-Ni )	IEC60584	-200 °C	1200 °C
Type-E ( Cr-Const )	IEC60584	-200 °C	1200 °C
Type-N ( Nicrosil-Nisil )	IEC60584	0 °C	1200 °C
Type-S ( Pt%10Rh-Pt )	IEC60584	0 °C	1500 °C
Type-R ( Pt%13Rh-Pt )	IEC60584	0 °C	1600 °C
Type-B ( Pt%18Rh-Pt )	IEC60584	0 °C	1800 °C
Pt-100	DIN 43760	-200 °C	850 °C
0 / 4-20 mA		0 mA	20 mA
0 / 2-10 VDC		0 VDC	10 VDC

### Device Dimensions

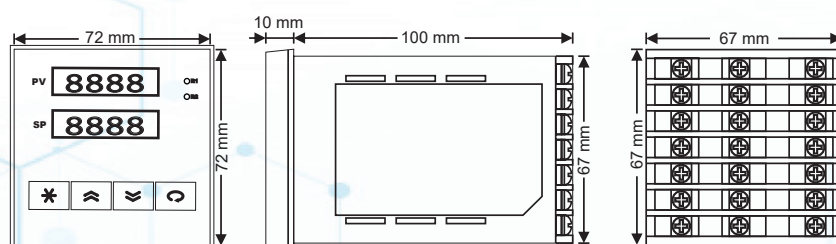

Panel Cutting Dimensions = 68 ± 0,5 mm x 68 ± 0,5 mm

## Technical Specifications

<b>Power Supply ( PS )</b>	100-240 Vac/dc +10%-15% Universal 24 Vac/dc +10%-20% Universal
<b>Power Consumption</b>	5W, 8VA
<b>Universal Sensor Input ( S1 )</b>	Thermocouple = B, E, J, K, L, N, R, S, T, U Two Wired Transmitter = 4-20mA Resistance Thermometer = Pt-100 Current = 0/4-20mA Voltage = 0-50mV, 0/2-10V
<b>Transmitter Supply ( TX )</b>	24Vdc ( I <sub>sc</sub> = 30mA )
<b>Analog Input Impedance</b>	Thermocouple, mV = 10MΩ Current = 10Ω Voltage = 1MΩ
<b>Analog Output ( O1 )</b>	Current = 0/4-20mA ( R <sub>L</sub> ≥500Ω ) Voltage = 0/2-10V ( R <sub>L</sub> ≥1MΩ )
<b>Relay Output ( R1,R2,R3 )</b>	Contact = 250VAC 10A Logic Output = 24Vdc 20mA
<b>Contact Lifetime</b>	No Load = 10.000.000 Switching 250V,10A Resistive Load = 1.000.000 Switching
<b>Memory</b>	100 Years, 100.000 Renewals
<b>Accuracy</b>	+/- 0,2%
<b>Sampling Time</b>	100 ms
<b>Environment Temperature</b>	Working = -10...+55°C Storage = -20...+65°C
<b>Protection Class</b>	Front Panel = IP54 Trunk = IP20
<b>Dimensions</b>	Width = 72 mm Height = 72 mm Depth = 110 mm
<b>Panel Cutting Dimensions</b>	68 +/- 0,5 mm x 68 +/- 0,5 mm
<b>Weight</b>	292 gr

## Modular Structure and Connection Diagram

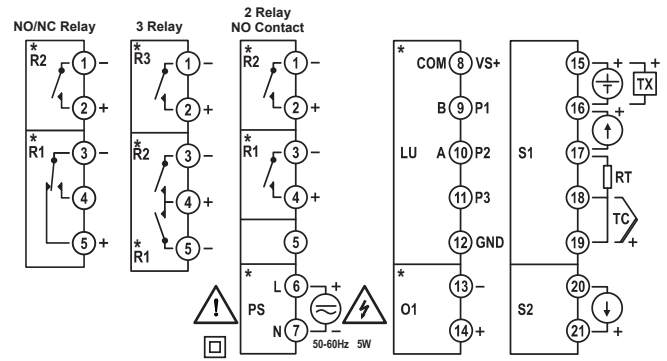

Module	Description
S1	Universal sensor input module (The sensor used to measure process value should be connected to the terminals with appropriate symbol on this module).
S2	It is not used in this model.
LU	This module is RS485 communication unit (The content of this module is determined by the product code, function is selected from the configuration page).
O1	Analog output (The content of this module is determined by the product code, function is selected from the configuration page).
R1,R2,R3	Relay output modules (The content of this module is determined by the product code, function is selected from the configuration page).
PS	Supply voltage input (Supply voltage is determined by product code).

## Product Code

SC771 - / 0 / 0

<b>Power Supply :</b> _____ PS	0 = 100-240Vac (Universal) 1 = 24Vac/dc
<b>Communication Module :</b> _____ LU	0 = N/A 3 = RS485 (MODBUS) Communication Module
<b>Analog Output Module :</b> _____ O1	0 = N/A 1 = 0/4-20mA Current Output 2 = 0/2-10Vdc Voltage Output
<b>R1 Output Module :</b> _____ R1	0 = N/A 1 = NO Contact 2 = 24V Logic Output ( to drive SSR ) 3 = NO/NC Contact
<b>R2,R3 Output Modules :</b> _____ R2-R3	0 = N/A 1 = NO Contact 2 = 24V Logic Output ( to drive SSR )