

Standard Rail Montage Control Device



RM100

Device Features

- 2 pcs 4 Digit Display
- 5 pcs LED Indicator
- 1 pcs Transmitter Supply Output (24VDC)
- 1 pcs Universal Sensor Input (TC, RT, mA, mV, V)
- 1 pcs Analog Output (0/4-20mA.0/2-10V)
- 1 pcs RS485 Communication Unit
- 5 pcs Relay or Logic Output (24VDC)
- 100-240V AC/DC Universal or 24V AC/DC Supply Voltage
- Isolation Between Input/Output Modules

- Auto-Tuning (Automatic settings of PID parameters)
- Sensor Error Detection
- 9 Different Relay Functions
- ON/OFF, P, PI, PID Controls
- Linear and Time Proportioning Control Output
- 100ms Sampling and Control Cycle
- Standard MODBUS RTU communication protocol
- Configuration via computer

RM100 devices are designed for the measurement of temperature, pressure, speed, level, humidity, current, voltage, resistance and other physical units, on / off and PID control of many process variables in industrial environments. They are completely modular and each module can be configured individually. It is used in Food, Plastic, Iron Steel, Chemistry, Metallurgy, Cement, Ceramic, Petro-Chemistry, Refineries, Glass and other industries. They are ergonomic devices whose compliance with international standards, reliability and ease of use have been ensured at the design stage.

Input Types

Sensor Type	Standard	Min.	Max.
Type-T (Cu-Const)	IEC60584	-200 °C	300 °C
Type-U (Cu-Const)	IEC60584	-200 °C	600 °C
Type-J (Fe-Const)	IEC60584	-200 °C	800 °C
Type-L (Fe-Const)	IEC60584	-200 °C	900 °C
Type-K (NiCr-Ni)	IEC60584	-200 °C	1200 °C
Type-E (Cr-Const)	IEC60584	-200 °C	1200 °C
Type-N (Nicrosil-Nisil)	IEC60584	0 °C	1200 °C
Type-S (Pt%10Rh-Pt)	IEC60584	0 °C	1500 °C
Type-R (Pt%13Rh-Pt)	IEC60584	0 °C	1600 °C
Type-B (Pt%18Rh-Pt)	IEC60584	0 °C	1800 °C
Pt-100	DIN 43760	-200 °C	850 °C
0 / 4-20 mA		0 mA	20 mA
0 / 2-10 VDC		0 VDC	10 VDC

Device Dimensions

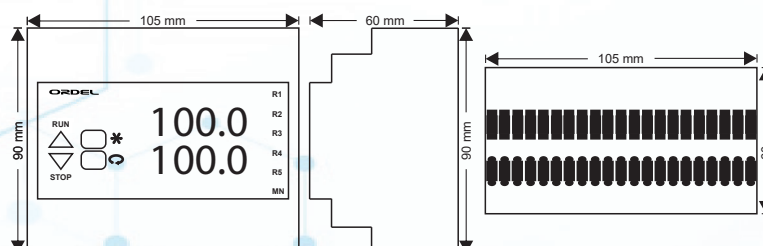

Technical Specifications

Power Supply (PS)	100-240 Vac/dc +10%-15% Universal 24 Vac/dc +10%-20% Universal
Power Consumption	6W, 10VA
Universal Sensor Input (S1)	Thermocouple = B, E, J, K, L, N, R, S, T, U Two Wired Transmitter = 4-20mA Resistance Thermometer = Pt-100 Current = 0/4-20mA Voltage = 0-50mV, 0/2-10V
Transmitter Supply (TX)	24Vdc (I _{sc} = 30mA)
Analog Input Impedance	Thermocouple, mV = 10MΩ Current = 10Ω Voltage = 1MΩ
Analog Output (O1)	Current = 0/4-20mA (R _L ≥500Ω) Voltage = 0/2-10V (R _L ≥1MΩ)
Relay Output (R1,R2,R3,R4,R5)	Contact = 250VAC 10A Logic Output = 24Vdc 20mA
Contact Lifetime	No Load = 10.000.000 Switching 250V,10A Resistive Load = 1.000.000 Switching
Memory	100 Years, 100.000 Renewals
Accuracy	+/- 0,2%
Sampling Time	100 ms
Environment Temperature	Working = -10...+55°C Storage = -20...+65°C
Protection Class	Front Panel = IP10 Trunk = IP10
Dimensions	Width = 105 mm Height = 110 mm Depth = 58 mm
Weight	430 gr

Modular Structure and Connection Diagram

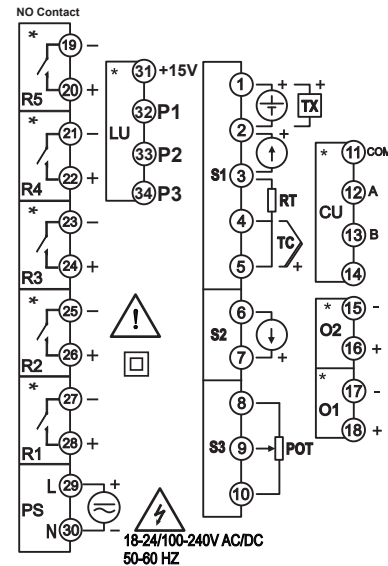

Module	Description
S1	Universal sensor input module (The sensor used to measure process value should be connected to the terminals with appropriate symbol on this module).
S2	It is not used in this model.
S3	It is not used in this model.
CU	RS485 MODBUS RTU module
LU	It is not used in this model.
O1,O2	Analog outputs (The content of this module is determined by the product code, function is selected from the configuration page).
R1,R2,R3,R4,R5	Relay output modules (The content of this module is determined by the product code, function is selected from the configuration page).
PS	Supply voltage input (Supply voltage is determined by product code).

Product Code

RM100 - 0 / 0 /

Power Supply : _____ PS
0 = 100-240Vac (Universal)
1 = 24Vac/dc

Communication Module : _____ CU
0 = N/A
3 = RS485 (MODBUS) Communication Module

Analog Output Module : _____ O1
0 = N/A
1 = 0/4-20mA Current Output
2 = 0/2-10Vdc Voltage Output

R1,R2,R3,R4,R5 Output Modules : _____ R1-R2-R3-R4-R5
0 = N/A
1 = NO Contact
2 = 24V Logic Output (to drive SSR)