

Pc1000

Step Controller USER GUIDE

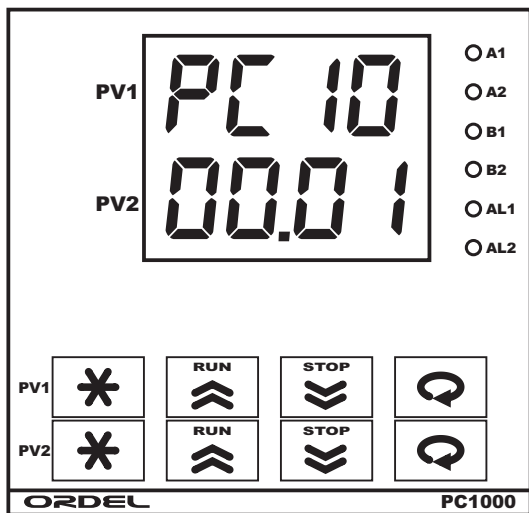

ORDEL



- Read this user manual carefully before using the device. Responsibility for accidents and damages caused by non-compliance with the warnings in this manual belongs to the user.
- This device has been produced for use by educated people in industrial enterprises, it is not suitable for use in homes and similar places for safety reasons.
- Do not use this device in the presence of flammable and explosive gases. It may cause explosion or fire due to electric arc that may occur at the contact points.
- Liquid substances and metal parts must be prevented from entering the device. Otherwise, it may cause accidents such as fire and electric shock.
- There is no fuse and circuit breaker on the device, they must be connected externally by the user.
- In case of malfunction of the device, external measures should be taken to prevent accidents and damages that may occur in the system in which it is located.
- It should be ensured that the sensor and signal cables are away from power cables or switched inductive load cables, or it must be prevented from being electrically affected.
- Before making the device connections, it should be checked whether the supply voltage is suitable for the place where it will be used by looking at the product code.
- Do not energize the device before making the connections related to the device in accordance with the wiring diagram and do not touch the terminals while the device is energized.
- The factory configuration of the device is not suitable for every system, it must be changed by the user according to the needs of the current system.
- The useful life of the device, as determined and announced by the Ministry, is 10 years.
- Do not modify or try to repair the device, the device should be repaired by authorized

EXPLANATION	Page No:
Warnings.....	2
Contents	3
Device Description.....	4
Preparation Stages for Use	5
Connection Diagram.....	6
Product Code.....	10
Technical Specifications	11
Temperature Sensors	12
Gösterge ve Tuş Fonksiyonları	13
Configuration	16
Configuration Page Parameters	18
Creating a Program	32
Program Page Parameters	33
Operator Page	32
Operator Page Parameters	36
Auto-Tune Operation	39
Operating Modes	40
Remote Setpoint Determination.....	41
Motorized Proportional Valve Control.....	42
Execution of Programs	43
Serial Communication.....	45
Configuration Guide.....	49
Notes	51

PC1000 Model devices are completely modular and each module can be configured independently, designed for the measurement and control of many process variables in industrial environments. In the design phase, compliance with international standards, reliability and ease of use are based. For this reason, they are ergonomic devices that can be used for very different controls in many sectors.

2 x 4 Digit Numeric Displays

6 LED Indicators

2 Transmitter Supply Outputs (24Vdc)

2 Universal Sensor Inputs (TC, RT, mA, mV, V)

2 Auxiliary Analog inputs (0/4-20mA)

2 Potentiometer Inputs (100-1500W)

4 Digital Inputs (15V)

2 RS485 Communication Units

2 Analog Outputs (0/4-20mA, 0/2-10V)

4 Relays or Logic Outputs (24V)

100-240Vac Universal or 24Vac/dc Supply

Isolation Between Input/Output Modules

800 Steps, 100 Program Steps Control

Possibility to Program Relay Positions in Steps

7 Different Energy Failure behaviors

Proportional Valve Control with Position Feedback

No-Feedback Proportional Valve Control (Floating Control)

PID Heating / Cooling

Auto-Tuning (auto-tuning of PID parameters)

Automatic / Manual / Programmed Operating Modes

Bumpless Transfer Feature

Sensor Troubleshooting

Remote Set Point

8 Selective Set Points

Ramp Function

Retransmission (For Process and Set value)

18 Different Relay Functions

ON/OFF, P, PI, PD, PID Control

Linear and Time-Proportional Control Output

100ms Sampling and Control Cycle

Standard MODBUS RTU Communication Protocol

Master-Slave, Cascade Control Applications

PC1000 Model devices are completely modular devices, therefore, before using the device, check the product code to see if the supply voltage and input-output modules are suitable.

- Before making other connections of the device, only supply the supply voltage and enter the configuration page to make the most suitable configuration for your system.
- After the device is properly configured, enter the program page and create the programs you want.
- Set the set values and hysteresis of the relays you have selected as alarms on the operator page.
- Cut off the power of the device and make other connections according to the connection diagram.
- Make the system to be controlled ready for operation and re-energize the system with the device.
- If the control outputs of the device will work as PID and you have not entered the PID parameters manually, perform Auto-Tune for the device to calculate these parameters itself.
- In order to be sure that the PID parameters found by Auto-Tune are correct, enter a new set value to the device and watch its operation.
- Check all the functions of the device by switching to other operating modes you will use.
- Finally, in order to prevent the intervention of unauthorized persons, enter the configuration page again and set the security-related parameters and return to the Process-Screen.

This user manual has been prepared in accordance with the above procedure. How to do these operations is given in detail in the relevant sections.

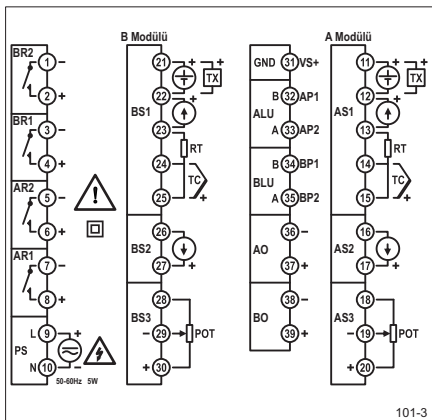
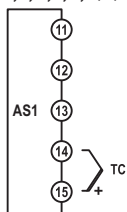

Figure -1

Module	Explanation
AS1	PV1 Universal sensor input module (The sensor used for process value measurement must be connected to the terminals with the appropriate symbol on this module).
BS1	PV2 Universal sensor input module (The sensor used for process value measurement must be connected to the terminals with the appropriate symbol in this module).
AS2	Module A "AS2" Auxiliary Analog Input module terminals.
BS2	Module B "BS2" Auxiliary Analog Input module terminals.
AS3	Module A "AS3" Potentiometer Input module terminals.
BS3	Module B "BS3" Potentiometer Input module terminals.

ALU	Logic Input or RS485 terminals connected to module "A" (Pv1).
BLU	Logic Input or RS485 terminals connected to the "B" (PV2) module.
AO	Analog Output module connected to "A" (PV1) input. (The content of these modules is determined by the product code, and their functions are determined by the "o 1F" parameters on the configuration page).
BO	Analog Output module connected to "B" (PV2) input. (The content of these modules is determined by the product code, and their functions are determined by the "o 2F" parameters on the configuration page).
AR1, AR2	"r 1F, r 2F" Relay Output modules connected to "A" module (PV1) input.
BR3, BR4	"r 3F, r 4F" Relay Output modules connected to "B" module (PV2) input.
PS	Supply voltage input (supply voltage is determined by the product code).

TC Input
(B,E,J,K,L,N,R,S,T,U)



RT Input (3 Wire)

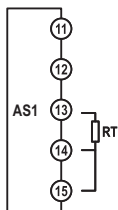

RT Input (2 Wire)

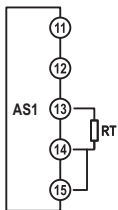

Current Input (mA)

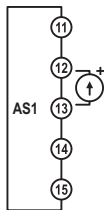

Voltage Input (V)

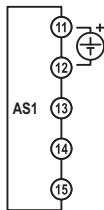

Transmitter Besleme
(24Vdc/30mA)

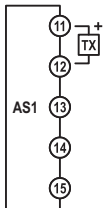

Assist. Current Input
(mA)

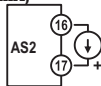

Proportional Feedback Link
(100 - 1500Ω)

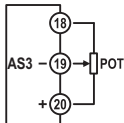

RS-485 Contact Connection*
(MODBUS - RTU)



Analog Output *
(0-20mA/0-10V)



Relay Outputs *



SSR Outputs*

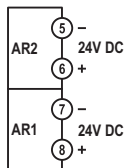

In two-wire connection number 14 and 15 terminals short circuit should be done.

* It is optional. Please refer to the Device Type Label.

TC Input
(B,E,J,K,L,N,R,S,T,U)

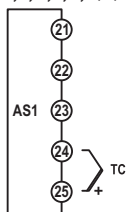

RT Input (3 Wire)

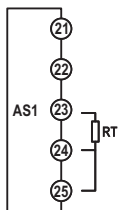

RT Girişi (2 Wire)

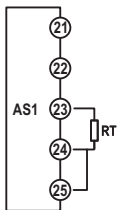

Current Input (mA)



Voltage Input (V)

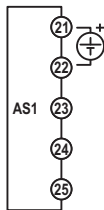

Transmitter Supply
(24Vdc/30mA)

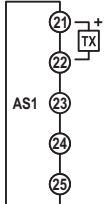

Assist. Current Input
(mA)

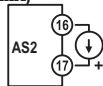

Proportional Feedback Link
(100 - 1500Ω)

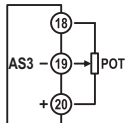

RS-485
Communication Link *
(MODBUS - RTU)



Analog Output *
(0-20mA / 0-10V)



Relay Outputs *

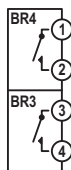

SSR Outputs *

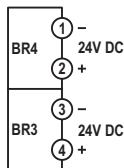

Logic Input
Connection *



In two-wire connection number 24 and 25 terminals short circuit should be done.

* It is optional. Please refer to the Device Type Label.

PC1000 -

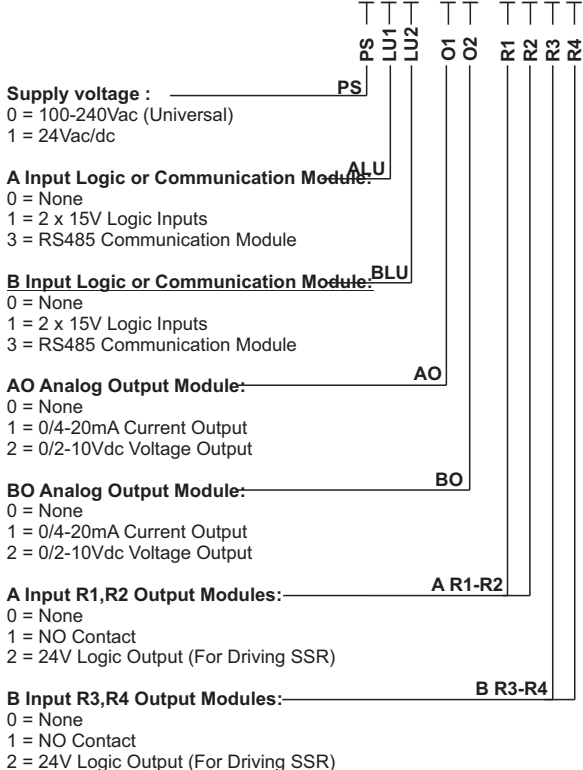

Relay output modules can be coded as contact or logic outputs in the product code, but only the term relay is used when talking about these outputs in this user manual.

Supply Voltage (PS)	100-240Vac/dc : +%10 -%15	24Vac/dc : +%10 -%20	
Power Consumption	6W,10VA		
Universal Sensor Input (AS1-BS1)	Thermocouple : B,E,J,K,L,N,R,S,T,U		
	Two wire Transmitter : 4-20mA		
	Resistance Thermometer : PT100		
	Current : 0/4-20mA		
	Voltage : 0-50mV, 0/2-10V		
Universal Sensor Input	0/4-20mA		
Potentiometer Input (AS3-BS3)	100-1500Ω		
Transmitter Supply (TX)	24Vdc (I _{sc} = 30mA)		
Analog Input Impedances	Thermocouple, mV : 10MΩ		
	Current : 10Ω		
	Voltage : 1MΩ		
Analog Outputs (AO,BO)	Current : 0/4-20mA (RL ≤	Voltage : 0/2-10V (RL ≥ 1MΩ)	
Relay Outputs(R1,R2,R3,R4)	Circuit: 250Vac, 5A	Logic Output: 24Vdc, 20mA	
Contact Life	No-load : 10.000.000 switching		
	250V, 5A Resistive Load: 100,000 switching		
Memory	100 yıl, 100.000 yenileme		
Accuracy	+/- %0.2		
Sampling Time	100ms		
Ambient temperature	Operation : -10...+55C	Storage : -20...+65C	
Protection Class	Front Panel: Ip54	Body : Ip20	
Dimensions	Width : 96mm	Height: 96mm	Depth : 110mm
Panel cut dimensions	92+/-0,5 mm x 92+/-0,5 mm		
Weight	430gr		

Sensor Type	Standard	Temperature Range	
		(°C)	(°F)
Type-B Thermocouple (Pt%18Rh-Pt)	IEC584-1	60, 1820	140, 3308
Type-E Thermocouple (Cr-Const)	IEC584-1	-200, 840	-328, 1544
Type-J Thermocouple (Fe-Const)	IEC584-1	-200, 1120	-328, 1562
Type-K Thermocouple (NiCr-Ni)	IEC584-1	-200, 1360	-328, 2480
Type-L Thermocouple (Fe-Const)	DIN43710	-200, 900	-328, 1652
Type-N Thermocouple (Nicrosil-Nisil)	IEC584-1	-200, 1300	-328, 2372
Type-R Thermocouple (Pt%13Rh-Pt)	IEC584-1	-40, 1760	104, 3200
Type-S Thermocouple (Pt%10Rh-Pt)	IEC584-1	-40, 1760	104, 3200
Type-T Thermocouple (Cu-Const)	IEC584-1	-200, 400	-328, 752
Type-U Thermocouple (Cu-Const)	DIN43710	-200, 600	-328, 1112
Pt-100 Resistance Thermometer	IEC751	-200, 840	-328, 1544

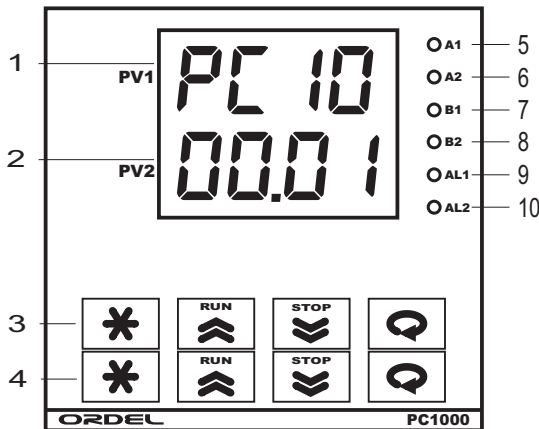

PROCESS-SCREEN:

When the device is energized, the program version is displayed on the gesterges for about 2 seconds, then the measured process value or error message of the A module is displayed on the “PV1” indicator, and the B module process value or error message is displayed on the “PV2” indicator. This screen is called the **Process-Screen**. This screen is used continuously during normal operation.

1	Pv1 INDICATOR	It displays the process value or error messages connected to the PV1 input on the Process-Screen, and the parameter name on the other displays.
2	Pv2 INDICATOR	It shows the process value or error messages connected to the PV2 input on the Process-Screen, and the parameter name on the other screens.
3	Pv1 SETTING KEYS	Keys used to set up Module A.
4	Pv2 SETTING KEYS	Keys used to set up Module B.
5	A1 LED	It lights when the “AR1” Relay module of module A is energized.
6	A2 LED	It lights when the “AR2” Relay module of module A is energized.
7	B3 LED	It lights when the “BR3” Relay module of module B is energized.
8	B4 LED	It lights when the “BR4” Relay module of module B is energized.
9	AI1 LED	Not used in this model.
10	AI2 LED	Not used in this model.





DISPLAY OF ALPHABETIC CHARACTERSi

A	B	C	D	E	F	G	H	I	J	K	L	M
A	b	C	d	E	F	G	H	I	J	K	L	M
N	O	P	Q	R	S	T	U	V	W	X	Y	Z
n	o	P	q	r	s	t	u	v	w	x	y	z

ERROR MESSAGES

Err.1	<p>If it appears on the “Pv1” screen, it means that the sensor at the “AS1” input cannot be detected.</p> <p>If it appears on the “Pv2” screen, it means that the sensor at the “BS1” input cannot be detected.</p>
Err.2	<p>If it appears on the “Pv1” screen, it means that the sensor at the “AS2” input cannot be detected.</p> <p>If it appears on the “Pv2” screen, it means that the sensor at the “BS2” input cannot be detected.</p>
Err.3	<p>If it appears on the “Pv1” screen, it means that the sensor at the “AS3” input cannot be detected.</p> <p>If it appears on the “Pv2” screen, it means that the sensor at the “BS3” input cannot be detected.</p>
----	<p>If it appears on the “Pv1” screen, it means that the value read from the “A” module input is too high to be displayed on the screen.</p> <p>If it appears on the “Pv2” screen, it means that the value read from the “B” module input is too high to be displayed on the screen.</p>
----	<p>If it appears on the “Pv1” screen, it means that the value read from the “A” module input is too low to be displayed on the screen.</p> <p>If it appears on the “Pv2” screen, it means that the value read from the “B” module input is too low to be displayed on the screen.</p>

KEY FUNCTIONS

	<p>While in the Process-Screen, a short press will reset the locked relays, When pressed for 5 seconds, the operating mode is changed. When the key is pressed together, then the key While on other screens, a short press will return to the beginning of the page, When pressed for 2 seconds, the Process-Screen is returned. </p>
	Used to change parameter option or values.
	Used to change parameter option or values.
	<p>A short press on any screen will move to the next parameter. When pressed for 5 seconds while on the Process-Screen, Auto-Tune operation is started. Press and hold for 2 seconds to confirm the conditions that require confirmation.</p>





Pc1000 Series devices are control devices designed for multi-purpose use. For this reason, they are devices with input/output modules suitable for all kinds of processes and can be used in accordance with all operating conditions. These devices can work with many different sensors and input signals, and each output can be used for a separate control. Therefore, before the PC1000 device can be used, the input/output types and functions, control type and usage characteristics should be set in the most appropriate way.









Depending on the order code, PC1000 series devices can have three analog inputs, three logic inputs, two analog outputs and four relay output modules. The types, functions and scales of these modules are determined by the parameters in the configuration page.

In addition, the basic parameters that determine the control type and operation of the device and the necessary settings for the control algorithm are also on the configuration page.

Before connecting an unconfigured device to your system, supply only the supply voltage and configure it according to the instructions below.

◆ ***Entering the configuration page and setting the parameters:***

Pc1000 has two independent universal input modules ("A" PV1 and "B" PV2) and other modules connected to these inputs. There are PV1 and PV2 keys to set the universal inputs "A PV1 and "B" PV2. In the normal display of the device (on the main screen), Process value or error messages are displayed. Parameter value is displayed when first  and then  keys are pressed together. The desired value is entered by using the  and  keys.

- ◆ To enter the configuration page, press and hold both the  and then  keys related to that module until the "E.2" message appears on the "PV1" indicator while the device is energized.
- ◆ While there is "E.2" message on the PV1 display, press the D and then A keys together, set the login password of the configuration page to the screen with the  and  keys (The factory setting of this password is "0").
- ◆ If the password you entered is incorrect when you press the  key, the Process-Screen is returned, and if it is correct, the first parameter on the configuration page is accessed.
- ◆ The name of the parameter appears on the "PV1" display on the parameter screen. Parameter value appears when first  and then  keys are pressed together.
- ◆ Now you can access other configuration parameters by pressing the  key.

- ◆ Use the "⏪" and "⏩" keys to change the setting option of the parameter, and the "⏴" key to move to the next parameter. Pressing the "⏴" key for a short time will return to the beginning of the page, while pressing the "⏴" key for a long time will return to the Process-Screen.
- ◆ The settings of the PV2 input are adjusted using the PV' keys in the same way as Pv1.
- ◆ **Figure-3** below is a graphical representation of these processes.

Note: Press the "⏴" and "⏩" keys together to see the numbers of the parameters on the configuration page to move forward.

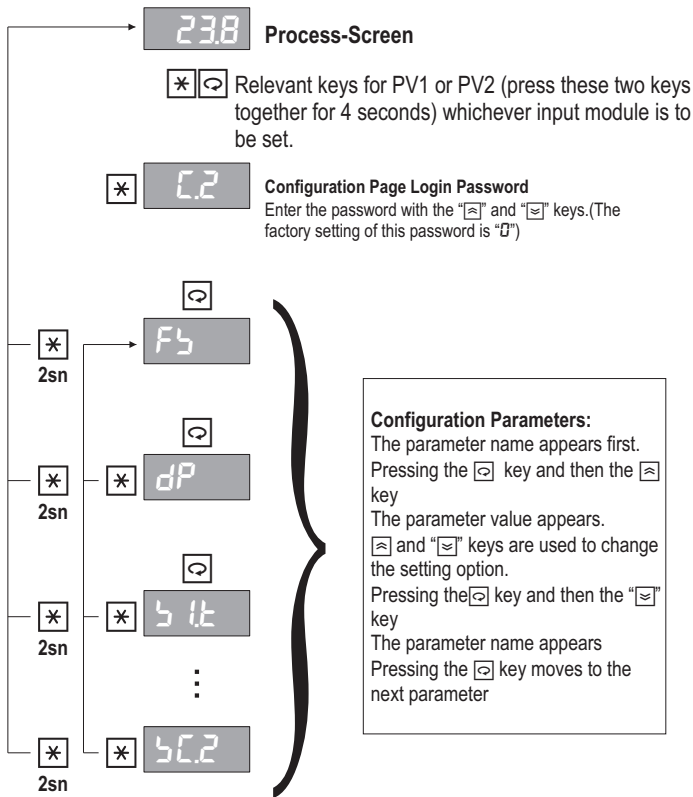

Figure-3

Detailed descriptions of the configuration page parameters are given in the next section.

Par. 01



To return to the factory settings, this parameter must be set to "00" and the "☐" key must be pressed for two seconds.

Setting Options: OFF, 00

Par. 02



It determines the decimal degree (number of digits after the dot) in the display of all parameters whose unit is "EU".

Setting Range : 0 - 3

Warning: When this parameter is changed, all parameters with unit "EU" must be set again.

Note: "EU" is the temperature unit determined by the "HU" parameter for temperature measurements with a thermocouple or resistance thermometer. In other cases, it is the engineering unit of the variable being measured.

Par. 03

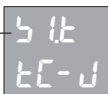

It determines the type of sensor connected to the universal sensor input "S1". This sensor is used for process value measurement.

Setting Options : : Table-1

Table-1	No	Sensor Type
tC-b	0	Type-B Thermocouple (Pt%18Rh-Pt)
tC-E	1	Type-E Thermocouple (Cr-Const)
tC-J	2	Type-J Thermocouple (Fe-Const)
tC-K	3	Type-K Thermocouple (NiCr-Ni)
tC-L	4	Type-L Thermocouple (Fe-Const)
tC-n	5	Type-N Thermocouple (Nicrosil-Nisil)
tC-r	6	Type-R Thermocouple (Pt%13Rh-Pt)
tC-S	7	Type-S Thermocouple (Pt%10Rh-Pt)
tC-t	8	Type-T Thermocouple (Cu-Const)
tC-U	9	Type-U Thermocouple (Cu-Const)
r t	10	Pt-100 Resistans Thermometer
0-50	11	0-50mV
0-20	12	0-20mA
4-20	13	4-20mA
0-10	14	0-10V
2-10	15	2-10V

Par. 04	<div style="font-family: monospace; font-size: 1.2em; padding: 5px;"> S1LL 00 </div>	"S1" It determines the lower scale value of the universal sensor input module. <i>Setting Range : -999.9 - 999.9</i>	<i>Unit : EU</i>																		
Par. 05	<div style="font-family: monospace; font-size: 1.2em; padding: 5px;"> S1HL 8000 </div>	"S1" It determines the upper scale value of the universal sensor input module. <i>Setting Range : -999.9 - 999.9</i>	<i>Unit : EU</i>																		
Par. 06	<div style="font-family: monospace; font-size: 1.2em; padding: 5px;"> S1bL H </div>	It determines the value of the scale if the sensor connected to the "S1" universal sensor input cannot be detected. <i>Setting Options : L (Lower value) , H (upper value)</i>																			
Par. 07	<div style="font-family: monospace; font-size: 1.2em; padding: 5px;"> S2F off </div>	It determines the function of "S2" Auxiliary analog input module. <i>Setting Options: Table-2</i>																			
<table border="1" style="width: 100%; border-collapse: collapse;"> <thead> <tr style="background-color: #cccccc;"> <th style="width: 15%;">Table-2</th> <th style="width: 10%;">No</th> <th style="width: 75%;">Analog Input Function</th> </tr> </thead> <tbody> <tr> <td>off</td> <td style="text-align: center;">0</td> <td>No</td> </tr> <tr> <td>RP_u</td> <td style="text-align: center;">1</td> <td>The measured value is added to the process value.</td> </tr> <tr> <td>S_P_u</td> <td style="text-align: center;">2</td> <td>The measured value is subtracted from the process</td> </tr> <tr> <td>PF_b</td> <td style="text-align: center;">3</td> <td>Used to read valve position.</td> </tr> <tr> <td>r_SP</td> <td style="text-align: center;">4</td> <td>It is used to determine the remote setpoint.</td> </tr> </tbody> </table>				Table-2	No	Analog Input Function	off	0	No	RP _u	1	The measured value is added to the process value.	S _P _u	2	The measured value is subtracted from the process	PF _b	3	Used to read valve position.	r _S P	4	It is used to determine the remote setpoint.
Table-2	No	Analog Input Function																			
off	0	No																			
RP _u	1	The measured value is added to the process value.																			
S _P _u	2	The measured value is subtracted from the process																			
PF _b	3	Used to read valve position.																			
r _S P	4	It is used to determine the remote setpoint.																			
Par. 08	<div style="font-family: monospace; font-size: 1.2em; padding: 5px;"> S2t 4-20 </div>	It determines the type of signal connected to "S2" Auxiliary analog input. <i>Setting Options : 0-20 (0-20mA) , 4-20 (4-20mA)</i>																			
Par. 09	<div style="font-family: monospace; font-size: 1.2em; padding: 5px;"> S2LL 00 </div>	"S2" It determines the lower scale value of the auxiliary analog input module. <i>Setting Range : -999.9 - 999.9</i>	<i>Unit : EU</i>																		
Par. 10	<div style="font-family: monospace; font-size: 1.2em; padding: 5px;"> S2HL 8000 </div>	"S2" It determines the upper scale value of the auxiliary analog input module. <i>Setting Range : -999.9 - 999.9</i>	<i>Unit : EU</i>																		

Par. 11	<div style="border: 1px solid black; padding: 5px; background-color: #cccccc;">52.6L</div> <div style="border: 1px solid black; padding: 5px; background-color: #cccccc;">H</div>	It determines the value of the scale if the signal connected to the "S2" auxiliary analog input module cannot be detected. <i>Setting Options</i> : L (Alt deęer) , H (Üst deęer)
Par. 12	<div style="border: 1px solid black; padding: 5px; background-color: #cccccc;">53F</div> <div style="border: 1px solid black; padding: 5px; background-color: #cccccc;">oFF</div>	It determines the function of "S3" Potentiometer input module. <i>Setting Options</i> : Table-2
Par. 13	<div style="border: 1px solid black; padding: 5px; background-color: #cccccc;">53LL</div> <div style="border: 1px solid black; padding: 5px; background-color: #cccccc;">00</div>	It determines the scale lower value of "S3" Potentiometer input module. <i>Setting Range</i> : -999.9 - 999.9 <i>Unit</i> : EU
Par. 14	<div style="border: 1px solid black; padding: 5px; background-color: #cccccc;">53HL</div> <div style="border: 1px solid black; padding: 5px; background-color: #cccccc;">8000</div>	It determines the upper scale value of "S3" Potentiometer input module. <i>Setting Range</i> : -999.9 - 999.9 <i>Unit</i> : EU
Par. 15	<div style="border: 1px solid black; padding: 5px; background-color: #cccccc;">53bL</div> <div style="border: 1px solid black; padding: 5px; background-color: #cccccc;">H</div>	It determines the value of the scale if the potentiometer connected to the "S3" Potentiometer input module cannot be detected. <i>Setting Options</i> : L (Alt deęer) , H (Üst deęer)
Par. 16	<div style="border: 1px solid black; padding: 5px; background-color: #cccccc;">HU</div> <div style="border: 1px solid black; padding: 5px; background-color: #cccccc;">°C</div>	It determines the temperature unit in temperature measurements with a thermocouple or resistance thermometer. <i>Setting Options</i> : °C (°C), °F (°F)
Par. 17	<div style="border: 1px solid black; padding: 5px; background-color: #cccccc;">t5u</div> <div style="border: 1px solid black; padding: 5px; background-color: #cccccc;">00</div>	It is added to the measured value to correct an error in temperature measurements with a thermocouple or resistance thermometer. <i>Setting Range</i> : -100.0 - 100.0 <i>Unit</i> : EU
Par. 18	<div style="border: 1px solid black; padding: 5px; background-color: #cccccc;">FtC</div> <div style="border: 1px solid black; padding: 5px; background-color: #cccccc;">2.0</div>	It determines the time constant of the digital filter applied to the analog inputs. When this value is increased, the reading stability increases, but the reading speed decreases. <i>Setting Range</i> : 0.1 - 10.0 <i>Unit</i> : sc
Par. 19	<div style="border: 1px solid black; padding: 5px; background-color: #cccccc;">LUF</div> <div style="border: 1px solid black; padding: 5px; background-color: #cccccc;">oFF</div>	It determines the function of the "LU" Logic input module. <i>Setting Options</i> : Table-3

Table-3	No	Logic Input Function
oFF	0	No
5P5	1	It is used for remote setpoint selection.
rLĈ	2	Used for remote program execution.

Par. 20		"It determines the function of O1" analog output module.	
		Setting Options: Table-4	

Table-4	No	Analog Output Function
oFF	0	No
PCo	1	PID control output in positive direction.
nCo	2	PID control output in negative direction.
Pvt	3	Process value transmission (Process Transmitter)
Svt	4	Set point transmission (Set Point Transmitter)



Par. 21		It determines the type of "O1" analog output module.	
		Setting Options : Table-5	

Table-5	No	Analog Output Type
0-20	0	0-20mA
20-0	1	20-0mA
4-20	2	4-20mA
20-4	3	20-4mA
0-10	4	0-10V
10-0	5	10-0V
2-10	6	2-10V
10-2	7	10-2V

Warning: In order to use the first four options, this module must be selected as "0/4-20mA" in the product code, and as "0/2-10V" for the last four options to be used.

Par. 22		If the "O1" analog output module is used as a transmitter, it determines the lower value of the output scale.	
		Setting Range: -999.9 - 9999.9	Unit : EU

Par. 23		If the "O1" analog output module is used as a transmitter, it determines the upper value of the output scale.	
		Setting Range: -999.9 - 9999.9	Unit : EU

Par. 24



It determines the function of "R1" Relay output module.

Setting Options : Table-6

Table-6	No	Relay Function	
oFF	0	No	
ULC	1	Upper limit Control	
LLC	2	Lower Limit Control	
ULR	3	Upper Limit Alarm	
LLR	4	Lower Limit Alarm	
UdR	5	Upper Deviation Alarm	
LdR	6	Lower Deviation Alarm	
obR	7	Out of Band Alarm	
ĩbR	8	In-Band Alarm	
PCo	9	PID control output in positive direction	
nCo	10	PID control output in negative direction	
POF	11	Positive control output warning	
NOF	12	Negative control output warning	
oPn	13	Proportional valve opening output	
ĬĬ	14	Proportional valve throttle output	

דבז	15	Control by serial communication
רזן	16	Program executing alert
פז	17	Program end warning
זזפ	18	Step alert

Note: The shaded regions in the alarm drawings are hysteresis regions and the hysteresis of each relay is determined by its own "זזז.נ" parameter. (Here the value indicated by "נ" is the relay number). "1"s in the alarm drawings indicate that the relevant relay is energized and "0"s mean that it is de-energized.

Par. 25		It determines the function of "R2" Relay output module.	
		Setting Options: Tablo-6	







Par. 26		It determines the lower limit of all set values.	
		Setting Range : זPLL - 9999	Unit : EU

Par. 27		It determines the upper limit of all set values.	
		Setting Range : זPLL - 9999	Unit : EU

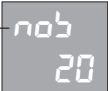
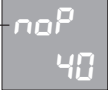
Par. 28		It is used in cold systems to prevent the output from exceeding 10% power until a certain set value is reached.	
		Setting Range : ז - OFF	

Par. 29		When Soft is activated, it determines how many degrees it will come out with 10% power.	
		Setting Range : 0 - 9999	

Par. 30		It determines the amount of progress in one hour if the control set value is desired to progress in the form of a ramp.	
		Setting Range : OFF , 0.1 - 999.9	Unit : EU

Par. 31		It determines the number of steps to be reserved for a program in step control programs.
		Setting Range : 1 - 100
		Warning: Previously written programs may break when this parameter is changed. For this reason, check the programs you have written before and rewrite them if necessary.
Par. 32		The step control determines the number of programs.
		Setting Range : 1 - 100
		Warning: The product of the number of steps allocated for a program and the number of programs should not exceed 800.
Par. 33		Determines the time unit in step control programs.
		Setting Options : SEC (second) , min (minute) , Hr (hour)
Par. 34		It determines the decimal degree of the time variable in step control programs.
		Setting Range : 0 - 1
Par. 35		It is used to wait for the measured value to enter the approach band of the set value at the end of each step.
		Setting Options : OFF (No) , ON (Yes)
Par. 36		It determines the approach band of the control set value in step control programs.
		Setting Range : 0.0 - 999.9
		Unit : EU
Par. 37		It determines the duration of the program end warning when the step control program is completed.
		Setting Range : CONT (continually), 1 - 600
		Unit : sc

Par. 38

5tC
oFF

It determines whether the control will be made according to a fixed set value when the step control program is not executed.

Setting Options : oFF(No) , oN(Yes)

Par. 39

PoR
Cnt

It determines how the program will continue in case of power cuts during the execution of step control programs.

Setting Options : Table-7

Table-7	No	Energy Outage Behavior
Cnt	0	The program continues where it left off..
APR	1	It starts in the "APPR" position. (The last set point and time are frozen, the process continues from where it left off when the value enters the approach band of the set value).
HLD	2	It starts in the "HOLD" position. (The last setpoint and time are frozen, continue from where it left off when the "RUN" command is given by the operator).
PLS	3	It starts at the "PLS" position. (Last setpoint and time are frozen, control output is interrupted, it continues from where it left off when "RUN" command is given).
R-P	4	It starts at the "PLS" position, when the "RUN" command is given, the control output becomes active and goes to the "APPR" position, and continues from where it left off when the process value enters the approach band of the set value.
H-P	5	It starts at the "PLS" position, when the "RUN" command is given, the control output becomes active and goes to the "HOLD" position, and when the "RUN" command is given again, it continues from where it left off.
brP	6	The program is terminated before it is finished.

Par. 40

CF
rEu

It determines the control form (Direction).

Setting Options : dCr (As the process increases so does the output), rEu (Output decreases as the process increases)







Par. 41





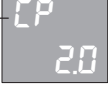

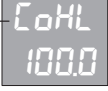
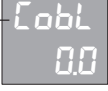

PoPb
oFF

It determines the proportional band of the PID control output in the positive direction.

Setting Range : oFF(ON/OFF control) , 0.1 - 9999

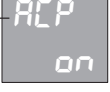
Unit : EU

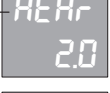
Par. 42		<p>It determines the proportional band of the negative direction PID control output.</p> <p>Setting Range : oFF (ON/OFF control) , 0.1 - 999.9 Unit : EU</p>
Par. 43		<p>Integral time constant</p> <p>Setting Range : oFF (Closed) , 1 - 6000 Unit : sc</p>
Par. 44		<p>Differential time constant.</p> <p>Setting Range : oFF (Closed) , 0.1 - 999.9 Unit : sc</p>
Par. 45		<p>Sets the duration of a control cycle. (Control Period)</p> <p>Setting Range : 0.1 - 60.0 Unit : sc</p> <p>Warning: In PID Control applications, the control period should be chosen very small compared to the system dead time in order to avoid oscillations caused by the control period</p>
Par. 46		<p>It determines the lower limit of the PID control output.</p> <p>Setting Range : 100.0 - [CoHL] Unit : %</p>
Par. 47		<p>Sets the upper limit of the PID control output.</p> <p>Setting Range : [CoLL] - 100.0 Unit : %</p>
Par. 48		<p>It determines the default value of the PID control output. (When the integral is closed, it is the control output value when the process value and the set value are equal)</p> <p>Setting Range : 100.0 - 100.0 Unit : %</p>
Par. 49		<p>When using bidirectional PID control, it determines the deadband when the control output changes direction.</p> <p>Setting Range : 0.1 - 25.0 Unit : %</p>

Par. 50		<p>Transition time of the proportional valve without feedback from fully closed position to fully open position. (This time should be determined by measuring)</p> <p><i>Setting Range: 10 - 2500</i> <i>Unit : sc</i></p>
Par. 51		<p>The proportional valve determines the dead band. When this value is increased, valve movements become more stable, but sensitivity decreases.</p> <p><i>Setting Range : 0.1 - 25.0</i> <i>Unit : %</i></p>
Par. 52		<p>Sub-calibration of the potentiometer connected to the "S3" input. While this parameter is on the screen, the potentiometer should be brought to the lowest position and this position should be saved by pressing the "☐" key for 2 seconds.</p>
Par. 53		<p>Upper calibration of the potentiometer connected to the "S3" input. While this parameter is on the screen, this position should be saved by bringing the potentiometer to the highest position and pressing the "☐" key for 2 seconds.</p>
Par. 54		<p>It determines which control type the Auto-Tune operation will be made according to.</p> <p><i>Setting Options : P, P L, P L d (P, PI, PID)</i></p>
Par. 55		<p>It enables the control period to be determined automatically by Auto-Tune operation.</p> <p><i>Setting Options : oFF (No) , on (Yes)</i></p>
Par. 56		<p>If Auto-Tune operation is desired to be performed at a certain set value, this set value is determined.</p> <p><i>Setting Range: oFF (Closed) , +99.9 - 999.9</i> <i>Unit : EU</i></p>
Par. 57		<p>It determines the hysteresis value used during Auto-Tune operation. It should be entered as 5-20 times the system instability.</p> <p><i>Setting Range : 0.1 - 100.0</i> <i>Unit : EU</i></p>
Par. 58		<p>It determines the serial communication address of the device. The communication addresses of the devices connected to a serial communication line should be selected differently from each other.</p> <p><i>Setting Range: oFF (Closed) , 1 - 255</i> <i>Unit : EU</i></p>

Par. 59	bAud 9.6	<p>Specifies the serial communication speed.</p> <p>Setting Options: 9.6 , 19.2 , 38.4</p> <p>Unit : Kbps</p>
Par. 60	Prty Eun	<p>It determines the parity type in serial communication.</p> <p>Setting Options: nonE(No) , odd(Single) , Eun(Couple)</p>
Par. 61	PrCb on	<p>It is the permission to change the step control program number by the operator.</p> <p>Setting Options : oFF(No) , on(Yes)</p>
Par. 62	nor3 off	<p>The step control program is the permission to change the number of repetitions by the operator.</p> <p>Setting Options: oFF(No) , on(Yes)</p>
Par. 63	CbP3 on	<p>It is the permission to change the control set value by the operator.</p> <p>Setting Options : oFF(No) , on(Yes)</p>
Par. 64	R3P3 on	<p>It is the permission to change the "bEEn" set values of the relays by the operator.</p> <p>Setting Options : oFF(No) , on(Yes)</p>
Par. 65	H333 on	<p>It is the permission to change the hysteresis values by the "H333" operator.</p> <p>Setting Options :oFF(No) , on(Yes)</p>
Par. 66	nC off	<p>It is the permission to enter Manual-Control mode.</p> <p>Setting Options : oFF(No) , on(Yes)</p>
Par. 67	AC off	<p>It is the permission to enter the Auto-Control mode.</p> <p>Setting Options : oFF(No) , on(Yes)</p>

Par. 68		Allows access to Programmed-Control mode. Setting Options: OFF (No) , ON (Yes)
Par. 69		It is the permission to switch to manual pause mode. Setting Options: OFF (No) , ON (Yes)
Par. 70		It is the permission to start Auto-Tune operation. Setting Options: OFF (No) , ON (Yes)
Par. 71		It determines whether the "CoL" parameter, which indicates the PID control output level, will appear on the operator page. Setting Options: OFF (No) , ON (Yes)
Par. 72		It automatically determines the return time to the Process-Screen while in the operator parameters.. Setting Range : OFF (No) , 1 - 25 Unit : sc
Par. 73		Sets the login password of the program page. Setting Range : 1999 - 9999
Par. 74		Sets the login password of the configuration page Setting Range : 1999 - 9999

Configuration parameters must be set separately for modules "A" (PV1) and "B" (PV2).

Time-based programs can be written to Pc1000 Series devices for the process to be controlled as follows. These programs consist of steps that determine the change of the set value according to time. A "time" and "target set value" are defined for each step, and the positions of the relays selected as "step warning" are determined. In these programs, the set value starts from the current process value and ends at the value determined by the "b5P" parameter in the configuration page.

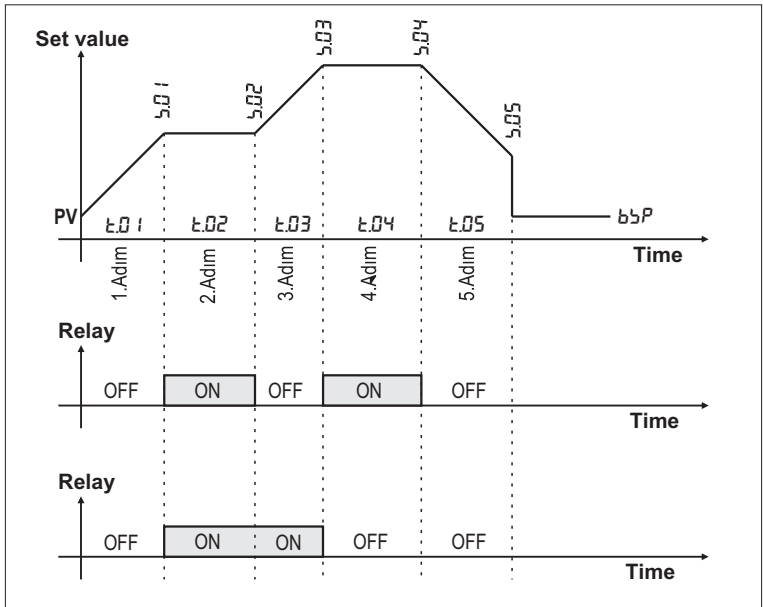

Before starting to write the program, the function of the relays to be used as "step warning" must be selected as "b5P" on the configuration page. In addition, the number of steps to be allocated to a program and the maximum number of programs to be written should be determined by the "n5P" and "n6P" parameters. These devices have a program memory of 800 steps, so the product of the parameters "n5P" and "n6P" should not exceed 800.

To create a program, enter the program page as in Figure-4 below and select a program number. By pressing the key, the parameters of the steps of this program are accessed and adjusted. To determine the end of the program, the duration of the last step is selected as "End" and the key is pressed for 2 seconds to return to the process screen.

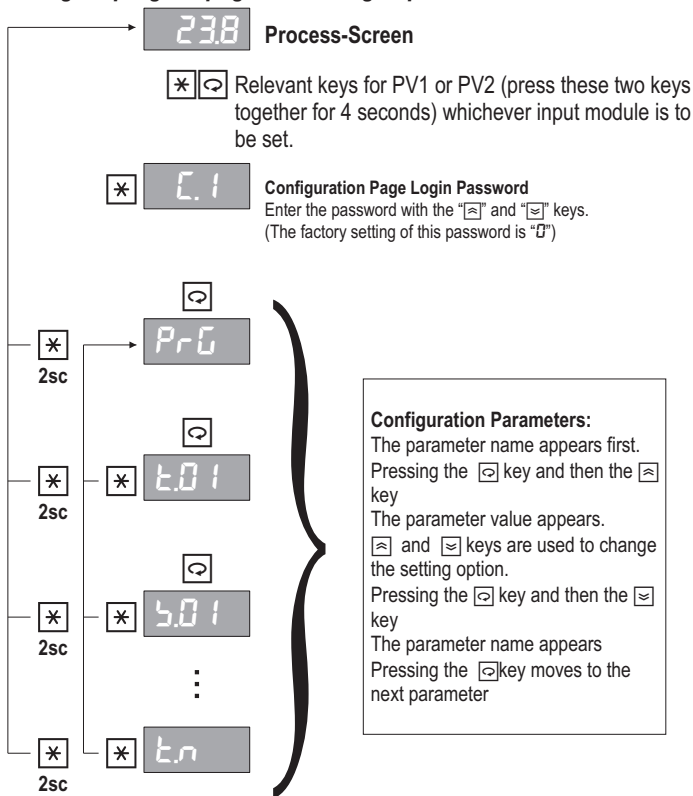
Entering the program page and setting its parameters:**Figure-4**

Detailed descriptions of the program page parameters are given in the next section.

	Program number	
	Setting Range: 1 - [nOP]	





	1. Step time.	
	Setting Options : Table-8 , 0.0 - 360.0	Unit : [tU]

Table-8	No	Explanation
<i>PPr</i>	-1	In this step, the control set value is kept constant at the target set value and when the process value enters the approach band of the control set value, the next step is taken. During this step, the message "PPr" flashes on the Process-Screen.
<i>HLd</i>	-2	In this step, the control set value is kept constant at the target set value and the next step is taken when the "RUN" command is given by the operator. During this step, the "HLd" message flashes on the Process-Screen.
<i>End</i>	-3	Indicates the end of the program. In the last step of each program, the step time should be selected as "End" .

	Target set value of step 1.	
	Setting Range : [5PLL] - [5PHL]	Unit : EU

	Determines the position of "R1" in Step 1. In order for this parameter to appear, the "r 1F" parameter must be selected as "5tP"	
	Setting Options : <i>off</i> (No energy) , <i>on</i> (Energy)	

	Determines the position of "R2" in Step 1. In order for this parameter to appear, the "r 2F" parameter must be selected as "5tP"	
	Setting Options : <i>off</i> (No energy) , <i>on</i> (Energy)	

	Determines the position of "R3" in Step 1. In order for this parameter to appear, the "r 3F" parameter must be selected as "5tP"	
	Setting Options : <i>off</i> (No energy) , <i>on</i> (Energy)	

d.01 off	<p>Determines the position of "R4" in Step 1. In order for this parameter to appear, the "r4F" parameter must be selected as "5EP".</p> <p>Setting Options: OFF (No energy) , ON(Energy)</p>
t.02 0.0	<p>2. Step Time.</p> <p>Setting Options: (Table-8) , 0.0 - 360.0</p> <p>Unit : [tU]</p>
s.02 0.0	<p>2. Target set value of the step.</p> <p>Setting Range : [sPLL] - [sPHL]</p> <p>Unit : EU</p>
R.02 off	<p>Determines the position of "R1" in Step 2. In order for this parameter to appear, the "r1F" parameter must be selected as "5EP".</p> <p>Setting Options: OFF (No energy) , ON(Energy)</p>
b.02 off	<p>Determines the position of "R2" in Step 2. In order for this parameter to appear, the "r2F" parameter must be selected as "5EP".</p> <p>Setting Options: OFF (No energy) , ON (Energy)</p>
⋮	⋮
t.n End	<p>n. Step time.</p> <p>Setting Options: (Table-8) , 0.0 - 360.0</p> <p>Unit : [tU]</p>

Warning: The value indicated by "n" is the last step number of the program. The duration of this step should be selected as "End".

Which of the parameters on the operator page will be used is determined according to the configuration and only the parameters to be used are displayed. These parameters, which are determined as a result of the configuration, are the parameters that are used continuously during normal operation, therefore, these parameters can be accessed by pressing the “☐” key at any time while on the Process-Screen, and by pressing the “*” key, it is returned to the Process-Screen. In order to see or change the value of the operator parameters, first the “☐” key, then the “≡” key is pressed and the parameter value is displayed. If the setting permission of the adjustable ones of these parameters is desired, they can be removed with the relevant parameters in the configuration page. If no key is pressed while in any parameter on the operator page, the Process-Screen is automatically returned when the time specified with the “RrL” parameter expires.

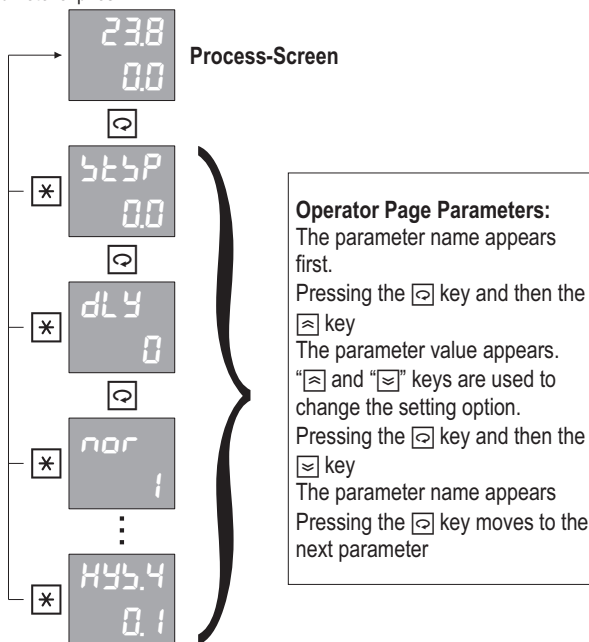

Detailed descriptions of the operator page parameters are given in the next section.

<p>Pu1 00</p>	<p>"S1" shows the value read from the universal sensor input. In order for this parameter to appear, the "b2F" or "b3F" parameters must be selected as "RPu" or "bPu".</p> <p style="text-align: right;">Unit : EU</p>
<p>Pu2 00</p>	<p>It displays the value read from the "S2" auxiliary analog input. For this parameter to appear, the "b2F" parameter must be selected as "RPu" or "bPu".</p> <p style="text-align: right;">Unit : EU</p>
<p>Pu3 00</p>	<p>It shows the value read from the "S3" potentiometer input. For this parameter to appear, the "b3F" parameter must be selected as "RPu" or "bPu".</p> <p style="text-align: right;">Unit : EU</p>
<p>bEbP 00</p>	<p>It is the fixed set value when the program is not executed. In the idle time between program executions, the control is done according to this set value.</p> <p style="text-align: right;">Unit : EU</p>
<p>dLY 0</p>	<p>It determines the delay time before the program. This time starts when the RUN command is given and the step number appears as 00. Execution of the selected program starts when this time expires.</p> <p style="text-align: right;">Unit : [tU]</p>
<p>nor 1</p>	<p>Before the program is started, it should be adjusted according to the desired number of repetitions. Indicates the number of repetitions remaining while the program is executing</p> <p style="text-align: right;">Setting Range : [onE] (Continuous Repetition) , 1 - 250</p>
<p>rEt 0.1</p>	<p>Shows the remaining step time.</p> <p style="text-align: right;">Unit : [tU]</p>
<p>PbP 00</p>	<p>It shows the instant walking set value.</p> <p style="text-align: right;">Unit : EU</p>
<p>CoL 00</p>	<p>Indicates the PID control output level. In order for this parameter to appear, the "CoP" parameter in the configuration page must be set to "on".</p> <p style="text-align: right;">Unit : %</p>

<p>PvP 00</p>	<p>Indicates the proportional valve position. In order for this parameter to appear, the "b2F" or "b3F" parameters in the configuration page must be selected as "PFb".</p> <p style="text-align: right;">Unit : %</p>
<p>b5P.1 00</p>	<p>1. It determines the optional set value. In order for this parameter to appear, the "LUF" parameter must be selected as "bPb".</p> <p>Setting Range : [bPLL] - [bPHL]</p> <p style="text-align: right;">Unit : EU</p>
<p>⋮</p>	<p>⋮</p>
<p>b5P.4 00</p>	<p>4. Determines the optional set value. In order for this parameter to appear, the "LUF" parameter must be selected as "bPb".</p> <p>Setting Range : [bPLL] - [bPHL]</p> <p style="text-align: right;">Unit : EU</p>
<p>bEt.1 00</p>	<p>It determines the set value of "R1" Module. In order for this parameter to appear, "rIF" parameter must be ALARM selected.</p> <p>Setting Range : [bPLL] - [bPHL]</p> <p style="text-align: right;">Unit : EU</p>
<p>⋮</p>	<p>⋮</p>
<p>bEt.4 00</p>	<p>"R4" Modülünün set değerini belirler. Bu parametrenin görünebilmesi için "r4F" parametresinin ALARM seçilmiş olması gerekir.</p> <p>Setting Range : [bPLL] - [bPHL]</p> <p style="text-align: right;">Unit : EU</p>
<p>HvB 0.1</p>	<p>Sets the control hysteresis value. In order for this parameter to appear, one of the proportional bands must be "OFF".</p> <p>Setting Range : 0.1 - 100.0</p> <p style="text-align: right;">Unit : EU</p>
<p>HvB.1 0.1</p>	<p>It determines the hysteresis value of the "R1" Module. In order for this parameter to appear, "rIF" parameter must be ALARM selected.</p> <p>Setting Range : LEL (Locked) , 0.1 - 100.0</p> <p style="text-align: right;">Unit : EU</p>
<p>⋮</p>	<p>⋮</p>
<p>HvB.4 0.1</p>	<p>It determines the hysteresis value of the "R4" Module. In order for this parameter to appear, "r4F" parameter must be ALARM selected.</p> <p>Setting Range : LEL (Locked) , 0.1 - 100.0</p> <p style="text-align: right;">Unit : EU</p>

When configuring PC1000 model devices, if the PID parameters (P_oP_b , r_oP_b , z_t , d_t , z_P) are left in their factory settings, the control outputs operate as ON/OFF. To start working as PID, these parameters must either be entered manually or Auto-Tune must be performed.

Since the characteristics of each process are different, the PID parameters should also be different. The Auto-Tune operation calculates and saves the most appropriate PID parameters for a process.

Before starting the Auto-Tune process, the " $RtSP$ " and " $RtHr$ " parameters on the configuration page should be set appropriately and the " Rt " parameter should be set to "ON". If the " $RtSP$ " parameter is left in the "OFF" state, Auto-Tune operation will be performed according to the current set value, so select a suitable set value. To obtain optimal PID parameters, the selected setpoint should correspond to the middle of the full power of the process.

After making the appropriate settings, start the Auto-Tune process by pressing the " \square " key for about 5 seconds while on the Process-Screen. " Rt " message flashes on "ST" indicator when Auto-Tune operation is started. In order for the results to be calculated properly, the device and the controlled system should not be interfered with during the Auto-Tune process. During the Auto-Tune process, the device calculates and saves the new PID parameters after performing an ON/OFF control of 2-3 oscillations according to the set value and hysteresis. When the Auto-Tune process is finished, the " Rt " message on the screen disappears and the device starts to control the system as PID with new parameters. After the auto tune process is completed, the " Rt " parameter in the configuration page should be set to "OFF" again.

If the " \times " key is pressed while the Auto-Tune process is in progress, the process is canceled.

If a device that works as PID is wanted to be operated as ON/OFF again, PID parameters must be set to factory settings.

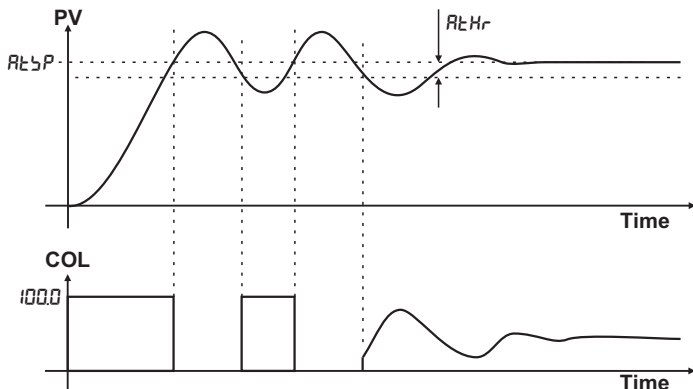

Pc1000 model devices can work in three different modes. These modes are called Auto-Control mode, Manual-Control mode and Programmed-Control mode, respectively. You can switch between these modes by pressing the " \boxtimes " key for 5 seconds while on the Process-Screen.

Undesirable operating mode can be turned off with the parameters "AC", "MC" and "PC" in the configuration page. When changing the operating mode, closed modes are skipped.

In PC1000 model devices, remote set point determination can be done in three different ways. These three methods are described separately below.

Determining the set point using the auxiliary analog input (Remote Set Point):

In order to determine the remote setpoint using the auxiliary analog input, the “52F” parameter in the configuration page must be selected as “r5P” and a scale must be determined with the “52LL”, “52HL” parameters.

Determining the set point using the potentiometer input (Remote Set Point):

In order to determine the remote setpoint using the potentiometer input, the “53F” parameter in the configuration page must be selected as “r5P” and a scale must be determined with the “53LL”, “53HL” parameters. In addition, the lower and upper positions of the potentiometer should be recorded with the parameters “53LE” and “53HE”

Determining the set value using the logic input module:

There are 3 logic inputs in the “ALU” and “BLU” logic input modules of these devices, and these inputs appear as P1, P2, P3 on the connection diagram, respectively. Both modules can be configured separately. If the “LUF” parameter in the configuration page is selected as “5P5”, 8 set values, “55P.1-55P.4”, appear on the operator page. These set values are optional set values and are selected as control set value according to the table below with the signal coming from P1, P2, and P3 inputs. When the selected setpoint is in automatic operation mode, it appears on the control setpoint display and is used as the control setpoint.



If optional set values and remote set values are used together, the remote set value is added to the 1st optional set value.

P1	P2	P3	Code	Explanation
0	0	0	55P.1	1. Optional setpoint
1	0	0	55P.2	2. Optional setpoint
0	1	0	55P.3	3. Optional setpoint
1	1	0	55P.4	4. Optional setpoint

Note: “1”s in the table mean that the input is energized, and “0”s mean that it is not energized. Inputs are energized by connecting the VS+ terminal to the corresponding input.



In order to execute a program written to PC1000 Model devices, the “” key must be pressed for 5 seconds while on the Process-Screen to enter the Programmed-Control mode.

When the “” and “A” keys are pressed together, the last selected program number appears in the first two digits of the PV1 indicator.

The program number to be executed is selected with the “” and “” keys and this program is started by giving the RUN command.







Commands given with keys:



RUN Command: It is given by pressing the “” and “” keys together, followed by the “” key first.

STOP Command: It is given by pressing the “” and “” keys together, followed by the “” key first.

Commands given with logic inputs:

In order to run a program remotely with the commands given from the logic inputs, the “LUF” parameter in the configuration page must be selected as “rLC”. These commands are shown in the table below.

P1		RUN		STOP
P2		PAUSE		Continue
P3		HOLD		Continue

When the “” and “” keys are pressed together while the program is running, the program number being executed in the first two digits of the indicator and the step number in the last two digits are displayed.

If the time of the executed step is selected as “RPr” or “HLd”, “RPPr” or “HoLd” message flashes during this step.

While the program is executing, the RUN command should be given to go to the next step without waiting, and the STOP command should be given to stop the program before it ends.

If the “nPE” parameter in the configuration page is set to “on”, the program switches to the “PRU” state at the first STOP command and the “PRU” message starts to flash on the ST indicator.

In PAUSE mode, all control outputs are closed, time and set value are frozen. If RUN command is given in this position, the program will continue from where it left off, if STOP command is given, it will be terminated completely.

By pressing the “” key while the program is running, the operator parameters can be accessed and the current status of the program can be monitored.

With PC1000 Model devices, motorized proportional valve control can be done in two ways, with and without feedback. Non-feedback valve control is also called Floating-Control.

In order to control the motorized valve, one of the relays of the device should be used to move the valve in the opening direction and the function of this relay should be selected as "oPn". Another relay should be used to move the valve in the throttling direction and the function of this relay should be selected as "CŁ 5"

If there is a feedback potentiometer on the valve, this potentiometer should be connected to the S3 input and the "53F" parameter should be selected as "PFb". In addition, the upper and lower values of this potentiometer should be recorded with the parameters "53L" and "53H". If a relay is reserved for turning on and throttling the motor and the system is ready to operate, the motor can be controlled manually with the "⊆" and "⊇" keys while these parameters are on the screen.

If "53F" parameter is not selected as "PFb", it means that feedbackless valve control (Floating-Control) will be performed.

In order to control the proportional valve without feedback, the time required for the valve to go from fully closed position to fully open position must be measured and entered in the "uŁŁ" parameter in the configuration page.

In motorized proportional valve control, the motor position is controlled according to the PID output. Therefore, PID parameters must be determined. If the PID parameters have not been determined manually, Auto-Tune must be performed in order for the device to determine these parameters

Below is a simple wiring diagram for motorized valve control.

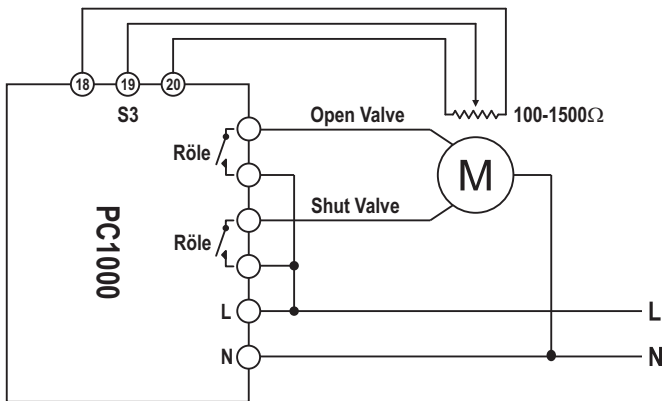

Motorized Proportional Valve Control

In addition, while the program is running, the set value and control output can be changed manually by changing the desired time operation mode. When returning to Programmed-Control mode again, the program will continue from where it left off.

While the program is running, the relays selected as step warning and programmed in steps are energized when the relevant step is reached.

When the program is finished, the relay defined as the program end warning is energized and remains energized for the time specified with the "FRL" parameter.

PC1000 Model devices are designed to be able to establish serial communication in slave mode with the standard MODBUS RTU protocol. With this communication, all parameters and variables in the device can be accessed. These parameters can be read and set.

Serial communication is via Half-Duplex RS485 line. 32 devices can be connected on a line.

The cable used in the communication line must be a shielded data cable suitable for Half-Duplex RS485 communication and this cable is connected to all devices in parallel as a single line. There must be a suitable terminating resistor at the beginning and end of the line. The length of a line that is prepared properly and has sufficient 9600 bps communication can be extended up to 1000 meters.

Each of the devices on the serial communication line must be given a separate communication address between 1 and 255, but the communication speed and parity type of all devices on a line must be the same. The communication address, communication speed and parity type of these devices are determined by the "*Addr*, *bAud* and *Prty*" parameters in the configuration page.

Supported functions, parameter addresses and other information required for communication in the standard MODBUS RTU protocol are given in the tables below.

Supported Standard MODBUS RTU Functions:

Function 01 = Read Coils

Function 03 = Read Holding Registers

Function 05 = Write Single Coil

Function 06 = Write Single Register

Function 16 = Write Multiple Registers

BIT Type Parameters (COILS)

Adres	Explanation (1 / 0)	Writin Perm.
0	Auto-Tune (ON / OFF)	
1	"R1" relay module (ON / OFF)	
2	"R2" relay module (ON / OFF)	
3	"R3" relay module (ON / OFF)	
4	"R4" relay module (ON / OFF)	
5	ERR1 Error (Yes/No)	No
6	ERR2 Error(Yes/No)	No
7	ERR3 Error (Yes/No)	No
8	General Error (Yes/No)	No
9	(RUN / STOP)	
10	PAUSE (Yes/No)	
11	HOLD (Yes/No)	
12	APPR (Yes/No)	No
13	FNS (Yes/No)	No

REGISTER Type Parameters (REGISTERS)

Address	Explanation	Setting Range		Factor	Unit	Writin Perm.
0	Current decimal degree	0	3	1		Yok
1	Measured process value	-1999	9999	10 [^] DP	EU	Yok
2	Control setpoint	-1999	9999	10 [^] DP	EU	
3	PID control output level	-1000	1000	10	%	
4	Working mode	0	2	1		
5	1. Process value measured from the sensor	-1999	9999	10 [^] DP	EU	Yok
6	2. Process value measured from the sensor	-1999	9999	10 [^] DP	EU	Yok
7	3. Process value measured from the sensor	-1999	9999	10 [^] DP	EU	Yok
8	Instant walking set value	-1999	9999	10 [^] DP	EU	Yok
9	Valve movement direction	0	2	1		Yok
10	Valve position	0	1000	10	%	Yok
11	Program number	1	100	1		
12	Non-program control setpoint	-1999	9999	10 [^] DP	EU	
13	Program delay time	0	3600	10 [^] TDP	TU	
14	Desired number of repetitions	0	250	1		
15	Remaining repetitions	0	250	1		Yok
16	Remaining repetitions	0	100	1		Yok
17	Time left to the end of the step	0	3600	10 [^] TDP	TU	Yok

Address	Explanation	Setting Range		Factor	Unit	Writing Perm.
20	1.Optional Setpoint	-1999	9999	10 ⁴ DP	EU	
21	2.Optional Setpoint	-1999	9999	10 ⁴ DP	EU	
22	3.Optional Setpoint	-1999	9999	10 ⁴ DP	EU	
23	4.Optional Setpoint	-1999	9999	10 ⁴ DP	EU	
24	5.Optional Setpoint	-1999	9999	10 ⁴ DP	EU	
25	6.Optional Setpoint	-1999	9999	10 ⁴ DP	EU	
26	7.Optional Setpoint	-1999	9999	10 ⁴ DP	EU	
27	8.Optional Setpoint	-1999	9999	10 ⁴ DP	EU	
28	"R1" The set value of the module	-1999	9999	10 ⁴ DP	EU	
29	"R2" The set value of the module	-1999	9999	10 ⁴ DP	EU	
30	"R3" The set value of the module	-1999	9999	10 ⁴ DP	EU	
31	"R4" The set value of the module	-1999	9999	10 ⁴ DP	EU	
32	Control hysteresis value	1	1000	10 ⁴ DP	EU	
33	"R1" The hysteresis value of the module	0	1000	10 ⁴ DP	EU	
34	"R2" The hysteresis value of the module	0	1000	10 ⁴ DP	EU	
35	"R3" The hysteresis value of the module	0	1000	10 ⁴ DP	EU	
36	"R4" The hysteresis value of the module	0	1000	10 ⁴ DP	EU	

Note: For contact information of other parameters, please contact the manufacturer.

Before starting to use the device, be sure to do the following operations in order by making use of this user manual.

- Make sure to select the $S1$ parameter according to the type of sensor you want to use. (**S1 Universal Sensor Input is in Table-1 on Page 15.**)
- Indicates the lower scale value of the data coming from the sensor connected to the S1 input for the application you want to make to the $S1L$ parameter.
- Indicates the upper scale value of the data coming from the sensor connected to the S1 input for the application you want to make to the $S1H$ parameter.
- Select the $r1F, r2F, r3F, r4F$ parameters according to the function you want to load on each relay. (The number of relay outputs is optional, it may differ. Relay Functions are listed in Table-6 on page 19 and page 20.)
- Select the $o1F, o2F$ parameters according to the function you want to load to each output. (The number of analog outputs is optional, it may differ. Analog Output Functions are listed in Table-4 on Page 18.)
- Select the $o1L, o2L$ parameter according to the current/voltage output type specified on the device label. (The number of analog outputs is optional, it may differ. Analog Output Type is listed in Table-5 on Page 18.)
- $o1L$, specifies the sub-scale value that you want the analog output module to output to the $o2L$ parameter. (The number of analog outputs is optional, it may differ.)
- $o1H$ specifies the upper scale value that you want the analog output module to output to the $o2H$ parameter. (The number of analog outputs is optional, it may differ.)

To make PID Control;

- If you want to use a Relay Output Module, select the Relay function of the relay output you want to use for PID control, from the $r1F, r2F, r3F, r4F$ parameters, from the $PCo, nCo, Pof, rnf, oPr, CLb, dBc$ options in the Relay Function table. Select the one that is suitable for the application you want to make.
- If you want to use an Analog Output Module, select the output module you want to use for PID control from the $o1F, o2F$ parameters, from the pco, nco options in the Analog Output Function table, which is appropriate for the application you want to make.

You can use the following two methods to control PID with our device:

- It specifies the PID control output proportional band value (P_{oPb}) in the positive direction, the PID control output proportional band value in the negative direction (n_{oPb}), the integral time clock (iT), the differential time constant (dT), and the duration of a control cycle. (C_P) parameters manually,
- By performing the Auto-Tune process, by enabling our device to automatically calculate the PID Control Parameters of the system in which it will be used,

To start the Auto-Tune Process:

- Enter the temperature set value at which Auto-Tune operation will be made to the $RtSP$ parameter. This value should come up to the middle of the full power of the process to be performed.
- Enter the hysteresis value used during Auto-Tune to the $RtHr$ parameter. (This value adjusts the sensitivity of the Auto-Tune operation of the device.)
- Set the Rt parameter to on

When the device is on the main standby screen, it is sufficient to press and hold the " \square " key for 5 seconds. While the Auto-Tune operation is being performed, the phrase Rt lights up and goes off on the device display. This expression disappears from the screen when Auto-Tune is finished. Auto-Tune operation can be canceled by pressing " \square " button while Auto-Tune operation is in progress.

www.ordel.com.tr

Üretici ve Teknik Servis : ORDEL Ltd. Şti. Uzuncağı Cad. 1252. Sok. No:12 OSTİM / ANKARA
Tel: +90 312 385 70 96 (PBX) Fax: +90 312 385 70 78

ORDEL