

## Advanced Control Device



# AC999

**RS485 communication and 2 logic inputs are provided as standard.**

### Device Features

- 2 pcs 4 Digit and 1 pcs 3 Digit Numeric Display
- 6 pcs LED Indicator
- 1 pcs Transmitter Supply Output (24VDC)
- 1 pcs Universal Sensor Input (TC, RT, mA, mV, V)
- 1 pcs Auxiliary Analog Input (0/4-20mA)
- 1 pcs Potentiometer Input
- 2 pcs Numeric Input (15V)
- 1 pcs Analog Output (0/4-20mA, 0/2-10V)
- 1 pcs RS485 Communication Unit
- 4 pcs Relay or Logic Output (24V)
- 100-240V AC/DC Universal or 24V AC/DC Supply Voltage
- Isolation Between Input/Output Modules

- The Difference Depends on The Two Control Inputs
- Proportional Valve Control With Position Feedback
- Proportional Valve Control Without Feedback
- PID Heating/Cooling
- Auto-Tuning (Automatic settings of PID parameters)
- Automatic/Manual Operating Modes
- Bumpless Transfer Ability
- Sensor Fault Detection
- Remote Set Point
- 4 Item Optional Setpoint
- Ramp Function
- Retransmission (For process and Set Value)
- 15 Different Relay Functions
- ON/OFF, P, PI, PD, PID Controls
- Linear and Time Proportioning Control Output
- 100ms Sampling and Control Cycle
- Standard MODBUS RTU Communication Protocol
- Master-Slave and Cascade Control Applications
- Configuration via Computer

AC999 are 96 x 96 mm in size. They are designed to measure the temperature, pressure, speed, level, humidity, current, voltage, resistance and other physical units, as well as the on / off and PID control of many process variables in industrial environments. They are completely modular and each module can be configured individually. It is used in Food, Plastic, Iron Steel, Chemistry, Metallurgy, Cement, Ceramic, Petro-Chemistry, Refineries, Glass and other industries. They are ergonomic devices whose compliance with international standards, reliability and ease of use have been ensured at the design stage.

### Input Types

Sensor Type	Standard	Min.	Max.
Type-T ( Cu-Const )	IEC60584	-200 °C	300 °C
Type-U ( Cu-Const )	IEC60584	-200 °C	600 °C
Type-J ( Fe-Const )	IEC60584	-200 °C	800 °C
Type-L ( Fe-Const )	IEC60584	-200 °C	900 °C
Type-K ( NiCr-Ni )	IEC60584	-200 °C	1200 °C
Type-E ( Cr-Const )	IEC60584	-200 °C	1200 °C
Type-N ( Nicrosil-Nisil )	IEC60584	0 °C	1200 °C
Type-S ( Pt%10Rh-Pt )	IEC60584	0 °C	1500 °C
Type-R ( Pt%13Rh-Pt )	IEC60584	0 °C	1600 °C
Type-B ( Pt%18Rh-Pt )	IEC60584	0 °C	1800 °C
Pt-100	DIN 43760	-200 °C	850 °C
0 / 4-20 mA		0 mA	20 mA
0 / 2-10 VDC		0 VDC	10 VDC

### Device Dimensions

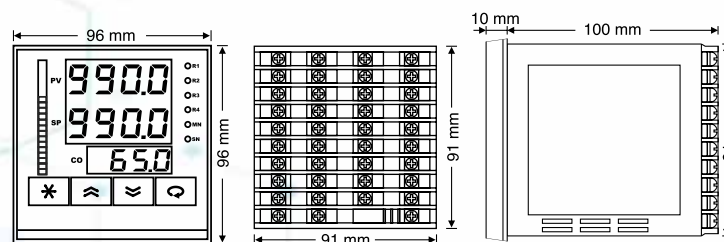

Panel Cutting Dimensions = 92 ± 0,5 mm x 92 ± 0,5 mm

## Technical Specifications

<b>Power Supply ( PS )</b>	100-240 Vac/dc +10%-15% 24 Vac/dc +10%-20%
<b>Power Consumption</b>	6W, 10VA
<b>Universal Sensor Input ( S1 )</b>	Thermocouple = B, E, J, K, L, N, R, S, T, U Two Wired Transmitter = 4-20mA Resistance Thermometer = Pt-100 Current = 0/4-20mA Voltage = 0-5mV, 0/2-10V
<b>Auxiliary Analog Input (S2)</b>	0/4-20mA
<b>Potentiometer Input (S3)</b>	100-1500Ω
<b>Transmitter Supply ( TX )</b>	24Vdc ( I <sub>sc</sub> = 30mA )
<b>Analog Input Impedance</b>	Thermocouple, mV = 10MΩ Current = 10Ω Voltage = 1MΩ
<b>Analog Output ( O1 )</b>	Current = 0/4-20mA ( RL≥500Ω ) Voltage = 0/2-10V ( RL≥1MΩ )
<b>Relay Output ( R1,R2,R3,R4 )</b>	Contact = 250VAC 10A Logic Output = 24Vdc 20mA
<b>Contact Lifetime</b>	No Load = 10.000.000 Switching 250V,10A Resistive Load = 1.000.000 Switching
<b>Memory</b>	100 Years, 100.000 Renewals
<b>Accuracy</b>	+/- 0,2%
<b>Sampling Time</b>	100 ms
<b>Environment Temperature</b>	Working = -10...+55°C Storage = -20...+65°C
<b>Protection Class</b>	Front Panel = IP54 Trunk = IP20
<b>Dimensions</b>	Width = 96 mm Height = 96 mm Depth = 110 mm
<b>Panel Cutting Dimensions</b>	92 +/- 0,5 mm x 92 +/- 0,5 mm
<b>Weight</b>	430 gr

## Modular Structure and Connection Diagram

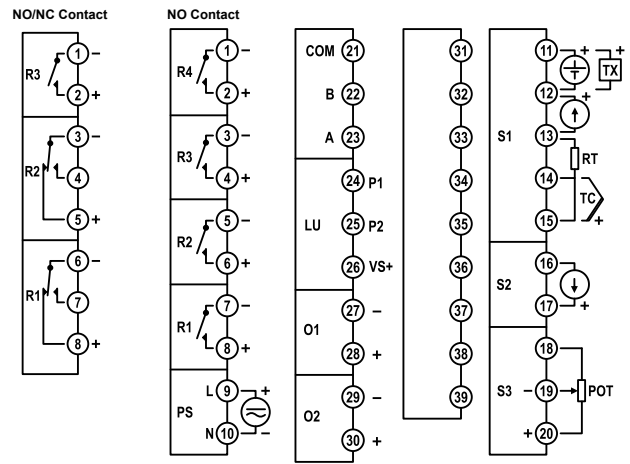

Module	Description
S1	Universal sensor input module (the sensor used to measure process value should be connected to the terminals with appropriate symbol on this module).
S2	0/4-20mA auxiliary analog input or analog output module.*
S3	100-15000Ω potentiometer input (The function of this module can be selected over the device).
S3/LU/CU	RS485 MODBUS RTU or Logic Input Module
O1,O2	Analog outputs (The content of this module is determined by the product code, function is selected from the configuration page).
R1,R2,R3,R4	Relay output modules (The content of this module is determined by the product code, function is selected from the configuration page).
PS	Supply voltage input (Supply voltage is determined by product code).

## Product Code

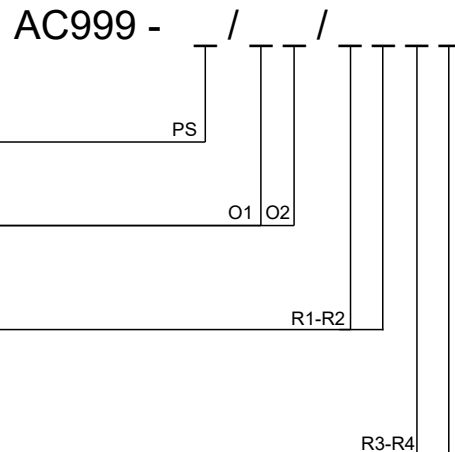

**Power Supply :** \_\_\_\_\_  
0 = 100-240Vac (Universal)  
1 = 24Vac/dc

**Analog Output Module :** \_\_\_\_\_  
0 = N/A  
1 = 0/4-20mA Current Output  
2 = 0/2-10Vdc Voltage Output

**R1,R2 Output Modules :** \_\_\_\_\_  
0 = N/A  
1 = NO Contact  
2 = 24V Logic Output ( to drive SSR )  
3 = NO/NC Contact

**R3,R4 Output Modules :** \_\_\_\_\_  
0 = N/A  
1 = NO Contact  
2 = 24V Logic Output ( to drive SSR )

**Note :** 1 pcs RS485 communication unit and 2 pcs logic (15VDC) are provided as standard.

*Note :* If R1 relay is coded as 3 (NO / NC), and relay R2 is selected as contact, it must be coded as NO / NC.  
If the R2 relay is coded as 3 (NO / NC), and the R1 relay is selected as a contact, it must be coded as NO / NC.  
If R1, R2 module is selected as 3, then R4 module must be coded as 0.